



More Precision

reflectCONTROL Sensor // 3D measurements & inspection of shiny surfaces



Sensor for high resolution inspection of shiny surfaces reflectCONTROL

Highest z-axis repeatability $\pm 1 \mu\text{m}$

Detects minor deviations $> 10 \text{ nm}$

Detailed analysis of surface quality

3DInspect: Powerful evaluation software with intuitive operating concept

Real 3D data via latest 3D GigE Vision standard

Easy integration in all common 3D image processing packets



3D sensor for the measurement and inspection of shiny surfaces

reflectCONTROL sensors offer an innovative solution for surface inspection, defect detection and geometry measurement on highly reflective and transparent surfaces. These sensors use phase-measuring deflectometry and enable full-surface measurement. In contrast to conventional visual inspection by humans, which involves a great deal of manpower and working time, the reflectCONTROL sensor delivers precise measurement results that allow a detailed analysis of the surface quality. Powerful software packages are available for evaluation and parameterization, which significantly improve the efficiency and accuracy of surface inspection.

Stationary use and robot-guided measurements

The compact deflectometry sensor can be integrated as a stationary system or guided over the measuring object by a robot. Software enables the visualization and evaluation of localized deviations and defects.

Models

2D Inspection

RCS110-245 2D

Page 6



- Measuring field 110 mm x 245 mm
- Intended for measurements of strongly reflecting, flat surfaces
- Output of 2D base intensity, amplitude and curvature images

* see examples on page 7

3D Geometry

RCS130-160 3D HLP

Page 10



- Measuring field 170 mm x 160 mm
- Intended for measurements of strongly reflecting, flat surfaces
- Output of 2D base intensity, amplitude and curvature images
- Output of 3D point clouds for high precision height measurements

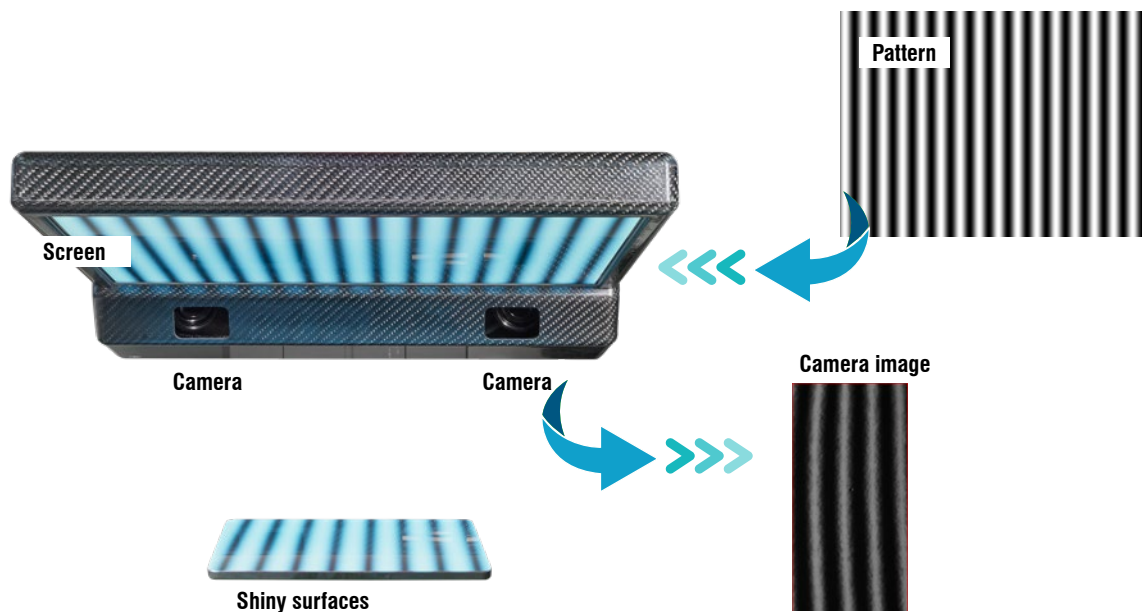

The reflectCONTROL sensors use phase-measuring deflectometry to precisely analyze shiny and transparent surfaces. A striped pattern is displayed on a screen and mirrored on the surface to be examined. This reflected mirror image of the pattern is captured by two cameras positioned behind the screen. The measurement data is processed into 2D images that show the structure of the surface. The RCS110-245 2D sensor is for creating high-resolution 2D images and thus enables a detailed examination of the surface in two dimensions. The RCS130-160 3D HLP sensor goes one step further and can calculate a 3D point cloud in addition to these 2D images. This point cloud provides a three-dimensional image of the surface structure and allows a high-precision analysis of irregularities, scratches and other defects.

Application examples
reflectCONTROL

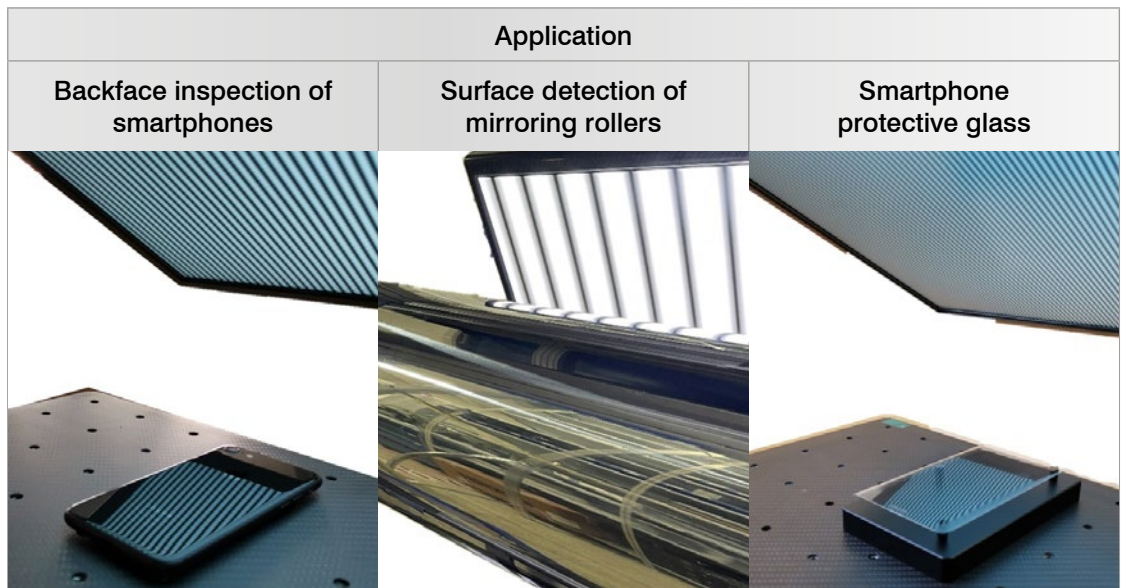

2D Inspection
 reflectCONTROL
 RCS130-160 3D HLP/
 RCS110-245 2D



Detection of minor deviations via curvature image

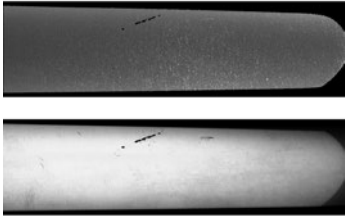

Defect detection possible in the curvature and amplitude images



Detection of various degrees of reflection in the amplitude image



3D Geometry
 reflectCONTROL
 RCS130-160 3D HLP

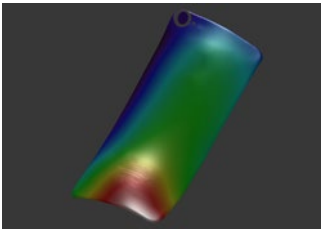

Deformation / Flatness in 3DInspect

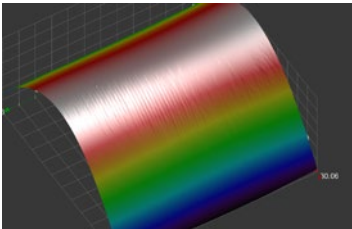

Flatness measurement in 3DInspect

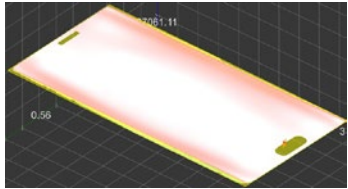

Measurement of flatness and clearance distances in 3DInspect

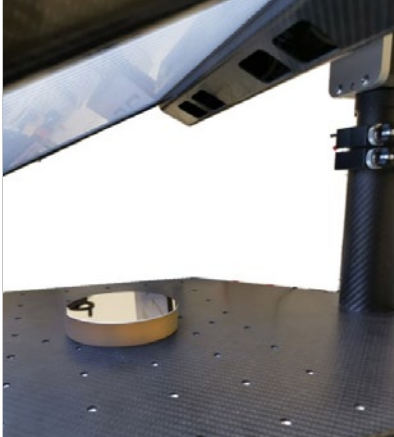
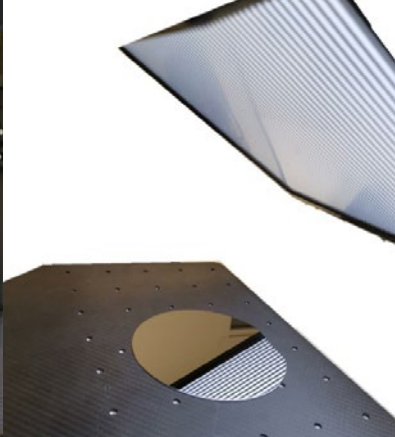
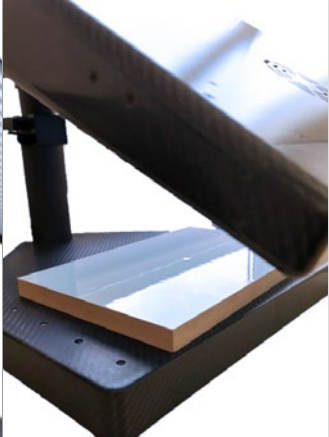
Application		
Surface characterization of round mirrors	Surface characterization of wafers	Laminated wood surface
		



2D Inspection
reflectCONTROL
RCS130-160 3D HLP/
RCS110-245 2D

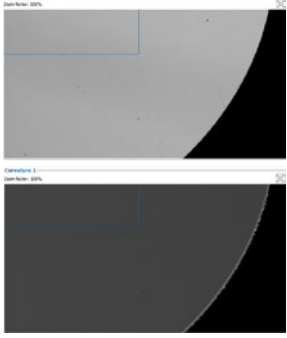

Detection of surface anomalies such as scratches, dust and notches

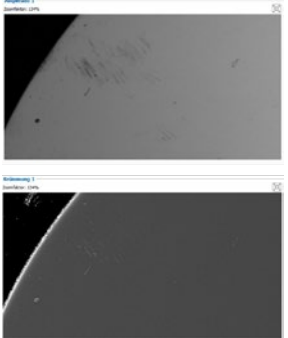

Detection of surface anomalies such as scratches, dust and notches

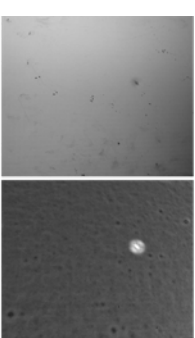

Detection of surface anomalies such as scratches, dust and notches



3D Geometry
reflectCONTROL
RCS130-160 3D HLP

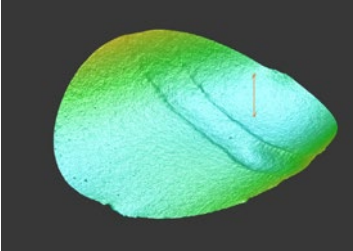

Flatness measurement in 3DInspect

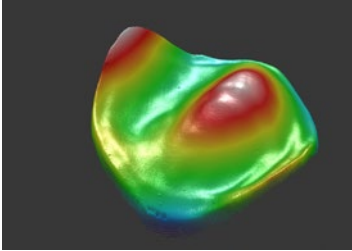

Flatness measurement in 3DInspect

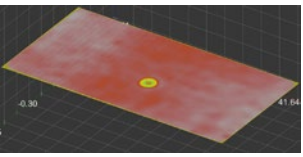

Detection and measurement of defect shape in 3DInspect

2D Surface inspection reflectCONTROL RCS110-245 2D

Highest z-axis repeatability $\pm 1 \mu\text{m}$

Detects minor deviations $>10 \text{ nm}$

Generation of highly accurate 2D phase images

Output of 2D base intensity, amplitude and curvature images

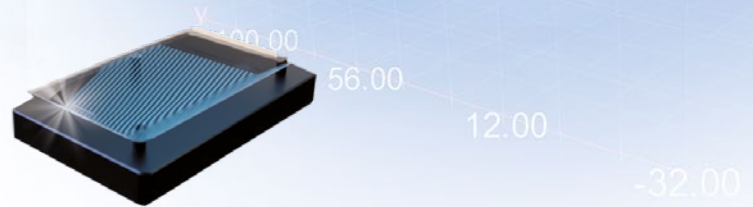
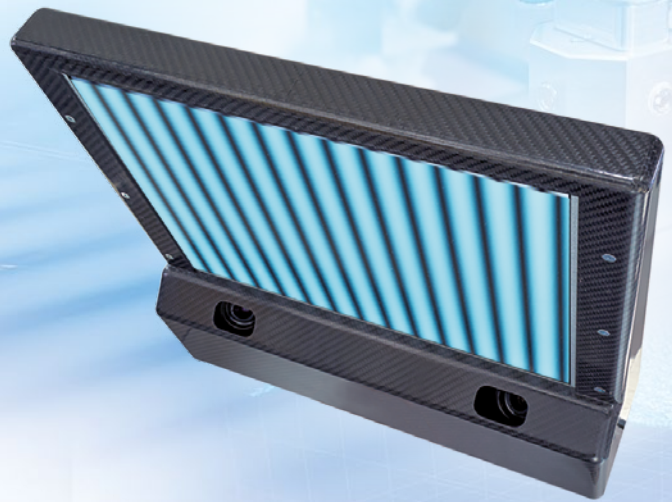

The reflectCONTROL sensor is specially designed for the inspection of shiny surfaces. The RCS110-245 2D model, equipped with an integrated controller, is suitable both for stationary measurements and for integration into machines. This compact sensor displays a striped pattern, which is projected onto the surface of the object to be inspected and captured by the sensor's cameras. Deviations in the striped pattern caused by irregularities on the surface are processed by the software and displayed as reflectivity and curvature images. These surface images can be transmitted via GigE Vision to various image processing software packages for further analysis.

Applications

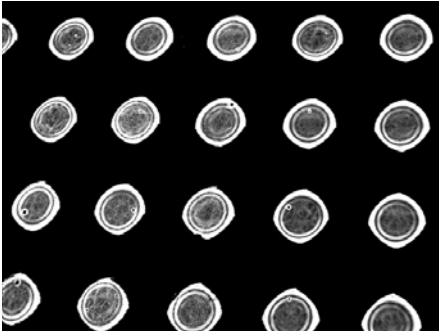

Defect detection of painted components

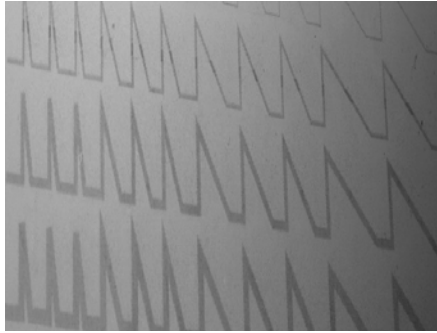

Detection of glass pattern

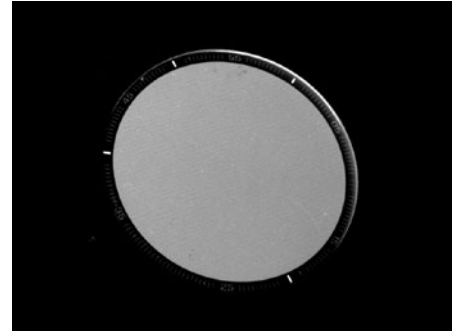

Defect detection on transparent measuring objects

Example

Pouch cells of a battery



The results are composed of:

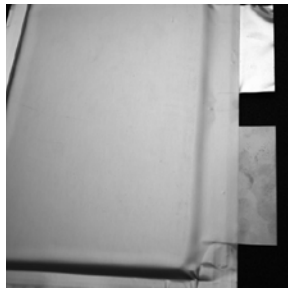

Base intensity image
Statement about
object brightness
Example: Changing light
absorption of surface

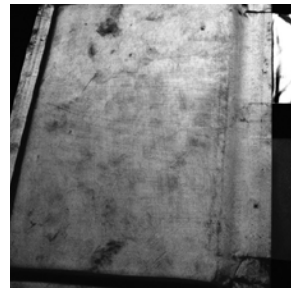

Amplitude image
Object reflectivity
Example: Detection of stains

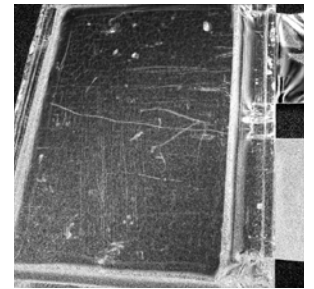

Curvature image
Anomalies in the surface
structure
Example: Detection
of scratches or dents

Defect detection

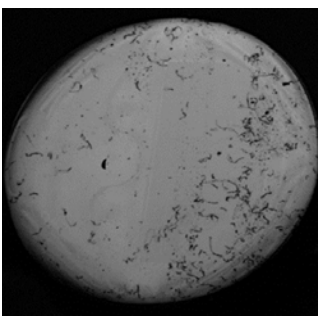

Dirt inclusions
Example: Molded plastics

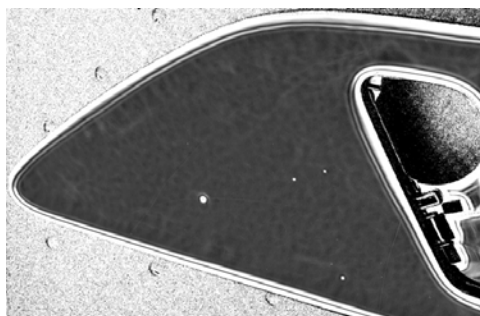

Defect detection
Example: High-gloss automotive interior components

Technical data and dimensions

reflectCONTROL RCS110-245 2D

Model		RCS110-245 2D
Measurement area Length x width (x * y) ¹⁾	in reference plane	116 mm x 245 mm
Acquisition of measurement data		typ. 0.6 s ... 2.7 s
Evaluation		typ. 0.5 s ... 2.4 s
Resolution	x,y	70 μ m
Supply voltage		24 V DC (must not exceed 26 V)
Power consumption		< 50 W
Interfaces and connections		1 x GigE Vision (RJ45), 1 x Ethernet (RJ45), power supply (3-pin Lemo connector)
Installation		mechanically reproducible adapter flange
Temperature range	Storage	-10° C ... 60 °C
	Operation ²⁾	0 °C ... 40 °C
Humidity		10% – 80%, non-condensing
Design		Carbon housing with controlled fan, design with integrated controller
Weight		< 7 kg

¹⁾ Size specifications refer to the reference plane. The medium width is specified. For exact dimensions see figure.

²⁾ For 2D measurements max. fluctuation of ± 2 °C after referencing

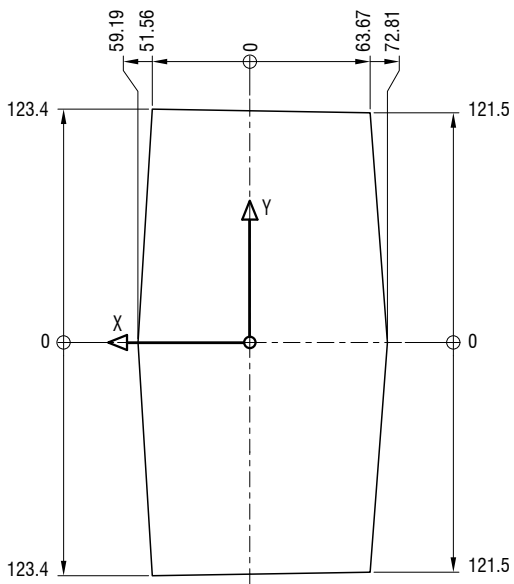
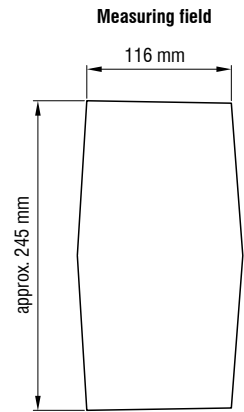
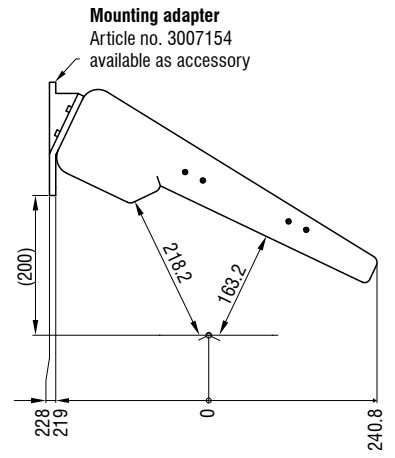
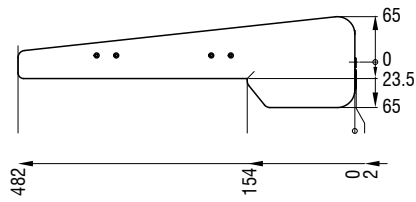
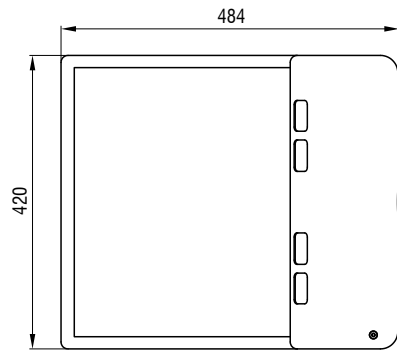
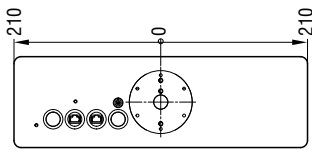

Sensor for high resolution 3D measurement reflectCONTROL RCS130-160 3D HLP

Highest z-axis repeatability $\pm 1 \mu\text{m}$

Detects minor deviations $>10 \text{ nm}$

Up to 5 million 3D points per measurement

3D data directly from the sensor

Real 3D data via latest 3D GigE Vision standard

Easy integration in all common 3D image processing packets



The reflectCONTROL RCS130-160 3D HLP sensor is designed for three-dimensional shape detection of shiny components. Similar to the 2D model, this sensor projects a striped pattern that is reflected across the object surface and captured by the sensor cameras. The key difference lies in the RCS130-160 3D HLP's ability to generate a detailed 3D representation of the surface, which can be used to accurately determine the topology of components, such as flatness, deflection and curvature. The RCS130-160 3D HLP is specially optimized for measurement and inspection tasks in production lines. It also has a GigE Vision interface and delivers GenICam-compliant data, enabling seamless integration into existing image processing systems.

3D surface reconstruction

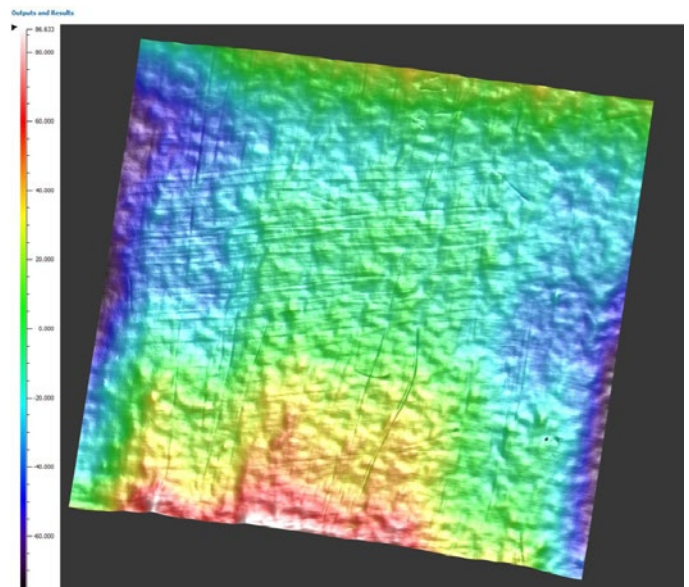
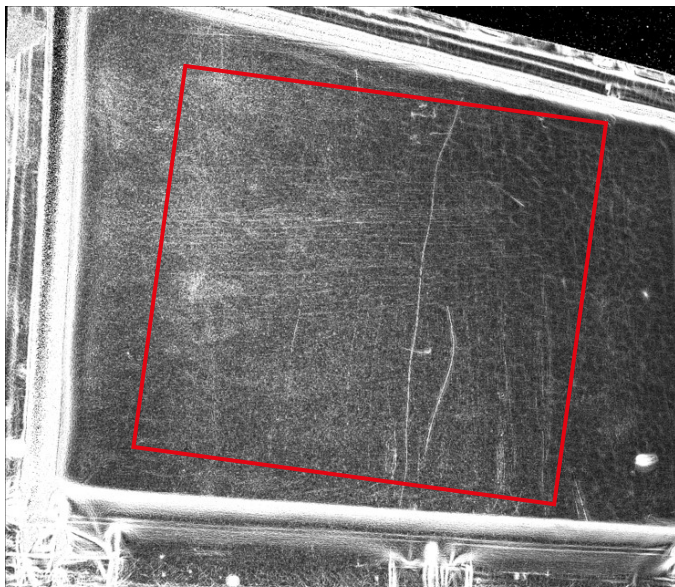

Applications

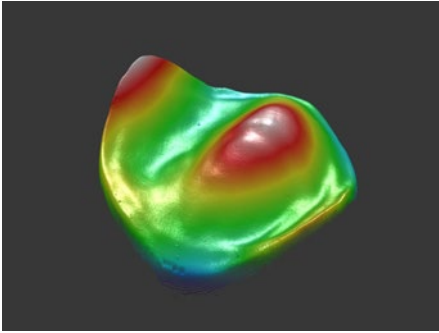

Flatness determination of wafers/mirrors/lenses

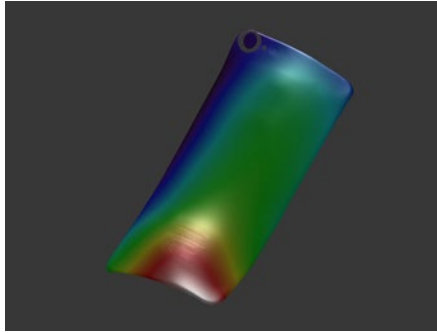

Shape and dimensional accuracy of smartphone

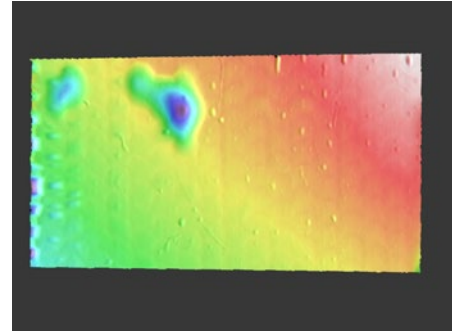

Measuring indentations and bumps, honeycomb composite material (aircraft construction)

Excellent repeatability, example of flat mirrors:

Flat mirror made of Zerodur Ø19 mm PV: $\lambda / 10$:

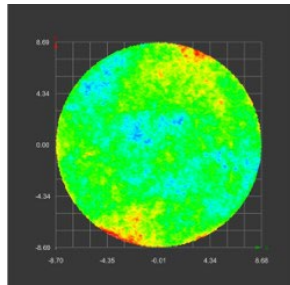

First measurement
PV: 22 nm
RMS: 2.8 nm

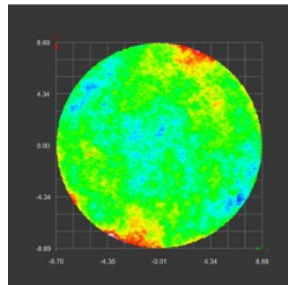

Second measurement
PV: 25 nm
RMS: 3.0 nm

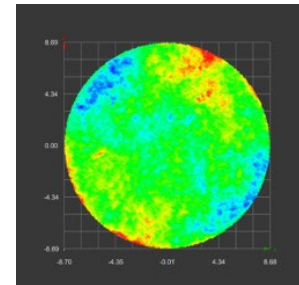

Third measurement
PV: 22 nm
RMS: 3.3 nm

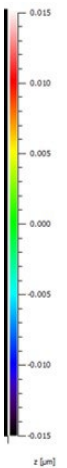

Flat mirror made of molybdenum Ø25 mm PV: $\approx \lambda / 1$

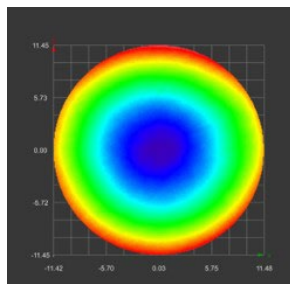

First measurement
PV: 471 nm
RMS: 119.6 nm

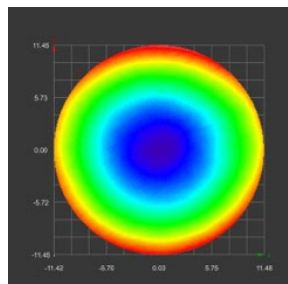

Second measurement
PV: 471 nm
RMS: 119.4 nm

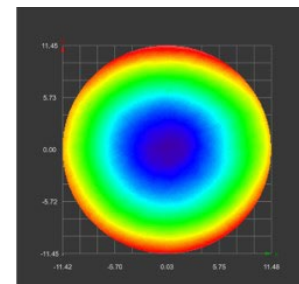

Third measurement
PV: 479 nm
RMS: 121.1 nm

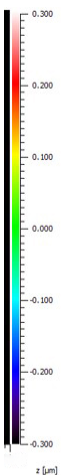

The comparison of all three measurements of both mirrors reveals that the deviation is extremely small. This underlines the exceptional repeatability of the reflectCONTROL RCS130-160 3D HLP A PV value (Peak-to-Valley) and an RMS value (Root Mean Square) are given for each measurement.

The PV value measures the maximum deviation between the highest and lowest points, while the RMS value calculates the average deviation from the ideal surface. These values confirm the precision and consistency of the results.

Technical data and dimensions

reflectCONTROL RCS130-160 3D HLP

Model	RCS130-160 3D HLP	
Measurement area Length (x) * width (y) at distance (z) ¹⁾	in reference plane	170 mm x 160 mm at 200 mm
Working distance	z	200 ±25 mm
		with working distance ±25 mm
	in measurement area A	15 µm
	in measurement area B	3.0 µm
	in measurement area C	1.5 µm
		with working distance ±0.5 mm
	in measurement area A	2.0 µm
	in measurement area B	0.75 µm
	in measurement area C	0.3 µm
Resolution	x, y	100 µm
Acquisition time		typ. 1 s ... 2 s
Processing time		typ. 2 s ... 3 s
Light source		LED screen
Supply voltage		24 V DC ³⁾
Power consumption		< 65 W
Digital interfaces		Gigabit Ethernet (GigE Vision / GenICam) / Ethernet, EtherNet/IP ⁴⁾ / EtherCAT ⁴⁾ / PROFINET ⁴⁾
Connection		RJ45 socket for GigE Vision (in/out); RJ45 socket for Ethernet (in/out); 3-pin. Lemo plug for power supply
Installation		mechanically reproducible adapter flange
Temperature range	Storage	-10 °C ... 60 °C
	Operation ⁵⁾	0 °C ... 40 °C
Max. humidity ⁶⁾		10 % ... 80 %, non-condensing
Protection class (DIN EN 60529)		IP20
Material		Carbon housing
Weight		< 7 kg
Sensor SDK		Micro-Epsilon 3D sensor SDK
3D evaluation software		Micro-Epsilon 3DInspect
Special features		carbon housing with controlled fan, design with integrated controller

Data valid if a maximum temperature difference of ±2 °C and a maximum humidity difference of ±2 % are maintained after referencing.

Measured on a λ/10 round mirror with a diameter of 300 mm.

¹⁾ Size specifications refer to the reference plane (trapezoidal measuring field). The medium width is specified. For exact dimensions see figure.

²⁾ Based on the entire measurement area of the sensor and five repeat measurements using all results. Standard deviation PV < 0.2 µm.

Exact segmentation of measurement areas see figure.

³⁾ The supply voltage must not exceed 26 V.

⁴⁾ Connection via interface module (see accessories)

⁵⁾ For 3D measurements max. fluctuation of ±2 °C after referencing

⁶⁾ For 3D measurements max. fluctuation of ±2 % after referencing

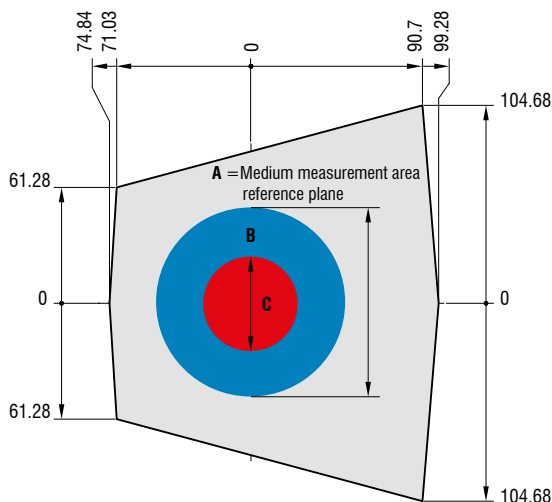

Flatness deviation with working distance ±25 mm

Measurement field	ø150 mm (total)	ø100 mm	ø50 mm
PV	15 µm	3 µm	1.5 µm
RMS	1.5 µm	0.75 µm	0.5 µm

Flatness deviation with working distance ±0.5 mm

Measurement field	ø150 mm (total)	ø100 mm	ø50 mm
PV	2 µm	0.75 µm	0.3 µm
RMS	0.5 µm	0.15 µm	0.05 µm

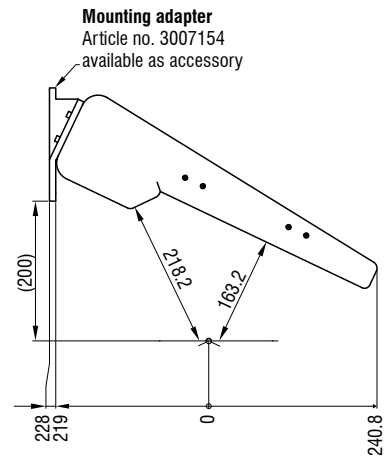
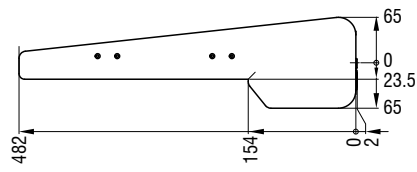
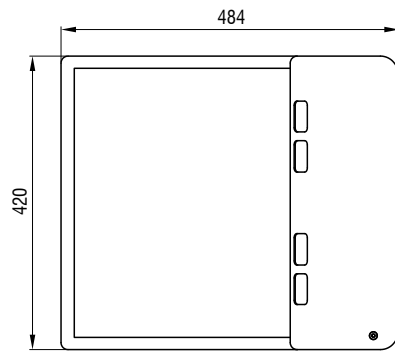
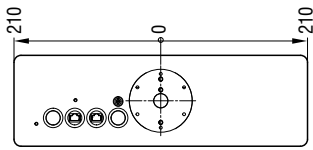

Measuring field

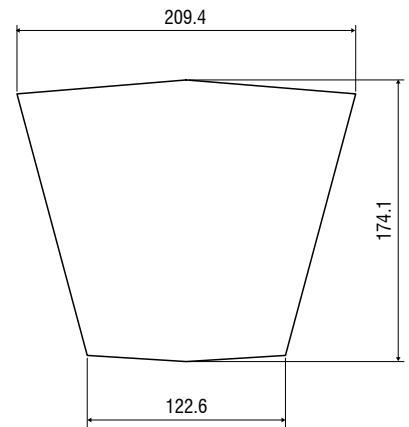

Software for 3D measurement and inspection tasks

3DInspect

Intuitive user interface

Real 3D evaluation, not just 2.5D

Automatic output of measured values for inline operation

Object extraction in 3D

Direct feedback with algorithms

Compatible with all 3D sensors from Micro-Epsilon



The 3DInspect software is a powerful tool for sensor parameter set up and industrial measurement tasks. This software transmits the measurement data from the sensor via Ethernet and provides the data in three-dimensional form. This 3D data is further processed, evaluated and assessed with 3DInspect measuring programs on the PC and, if necessary, logged and transmitted via Ethernet to a control unit. Furthermore, the software enables the storage of 3D data.

In addition, reflectCONTROL sensors can be referenced with a plane standard (plane mirror). The software also enables pre-processing of the data obtained (e.g. planarity fit) and to directly output the data as PV and RMS values.

Valid3D technology from Micro-Epsilon vs. conventional 2.5D systems

Valid3D:
Real 3D
without
data loss

The unique Valid3D technology enables lossless display and processing of the point clouds. This is how scanned 3D objects can be moved arbitrarily in the coordinate system.

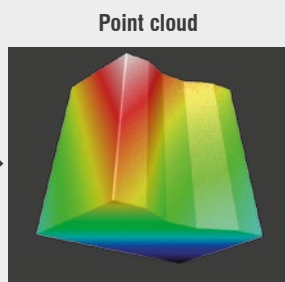
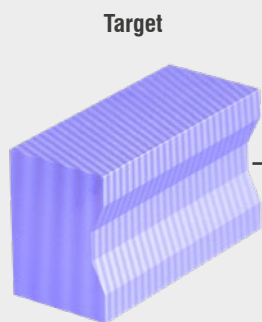

Point cloud after turn

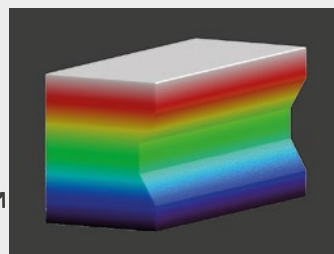

3DInspect with Valid3D

- Real 3D image of test object without data loss
- Analysis and evaluation of complete test object

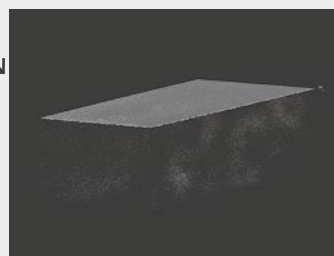

Common 3D software

- Algorithms based on 2.5D
- Only one z-coordinate per x/y coordinate possible
- Data loss during data processing

Software integration via Micro-Epsilon's 3D-SDK

reflectCONTROL is equipped with a user-friendly SDK (Software Development Kit). The SDK is based on the GigE Vision and GenICam industry standards including the following essential function blocks:

- Network configuration and sensor connection
- Control of data transmission (3D measurement data, video images, profile counters, ...)
- Comprehensive sensor control
- User sets
- Documentation
- C++ example programs
- 3D Viewer



Industrial Performance Unit

Powerful computer platform for 3DInspect

The Industrial Performance Unit offers integrated interfaces for connection to the industrial fieldbuses PROFINET, EtherCAT and Ethernet/IP. Prepared device description files allow easy integration into the respective control environment. For reliable communication, the sequential control model developed by Micro-Epsilon is available for smooth commissioning. It is available as an implementation example for typical controllers.

- High-performance solution for 3D measurement tasks
- Full compatibility and inline capability for customer applications
- Intuitive 3DInspect software with Valid3D technology
- Efficient commissioning of Micro-Epsilon sensors
- Industrial-grade hardware with passive cooling

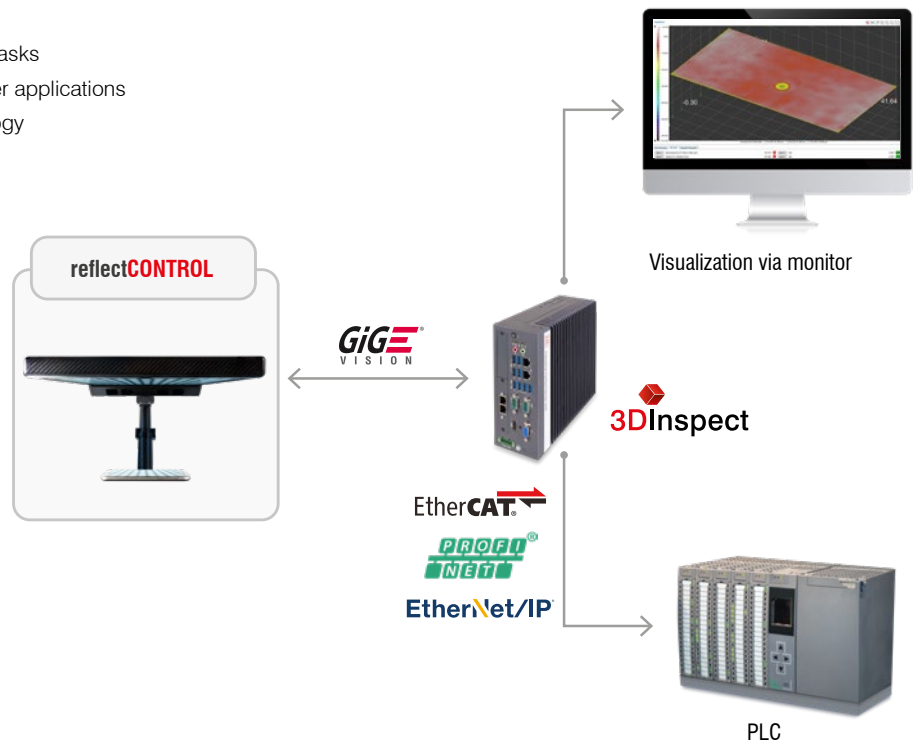

Sensors and Systems from Micro-Epsilon



Sensors and systems for displacement, distance and position



Sensors and measurement devices for non-contact temperature measurement

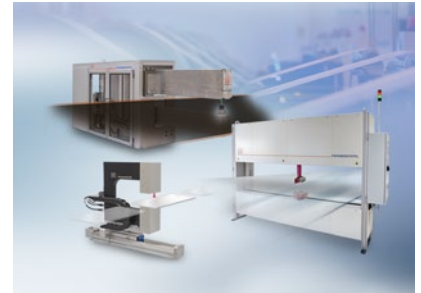

Measuring and inspection systems for metal strips, plastics and rubber



Optical micrometers and fiber optics, measuring and test amplifiers



Color recognition sensors, LED analyzers and inline color spectrometers

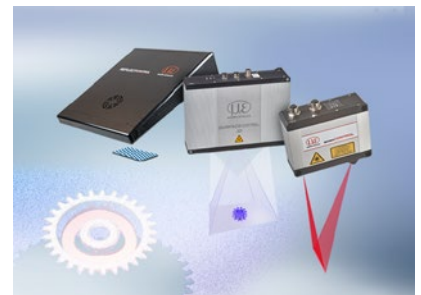

3D measurement technology for dimensional testing and surface inspection